

Experimenting – Learning – Understanding

Installation Technology – Selected basic circuits

Circuit for two lights

Circuit diagram (assembled)/
Installation plan

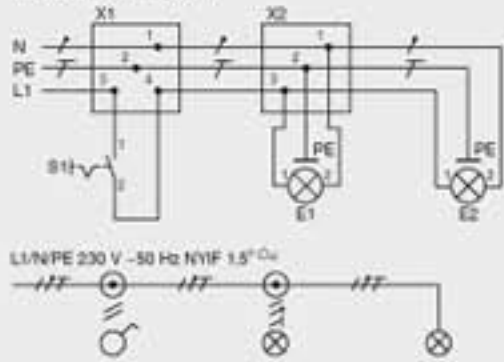

Circuit diagram (exploded)

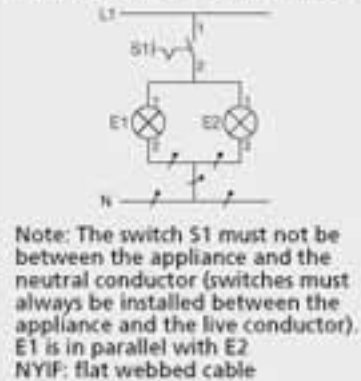

Circuits for fluorescent lights

Inductive circuit

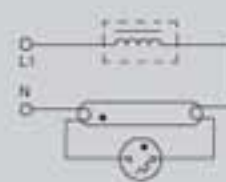

Series circuit

Circuit diagram (assembled)/
Installation plan

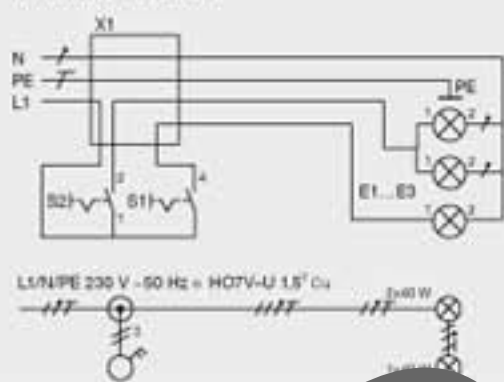

Circuit diagram (exploded)

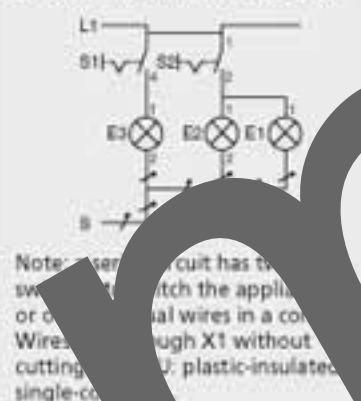

Induction-capacitive circuit

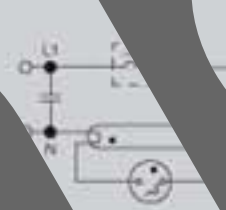

Two-way circuit

Circuit diagram (assembled)/
Installation plan

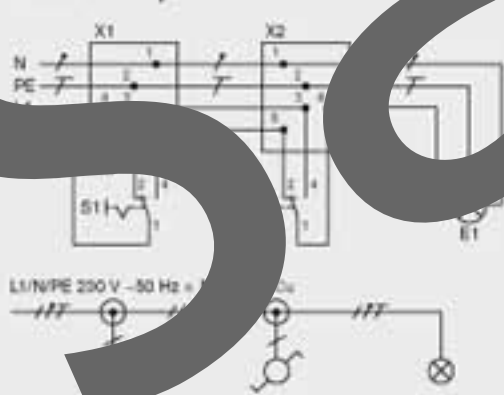

Circuit diagram (exploded)

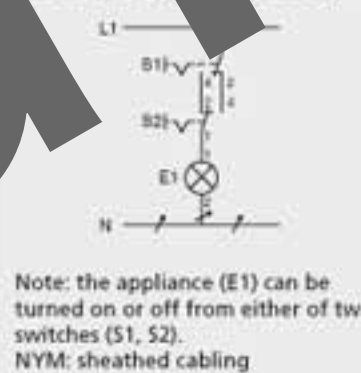

Duo circuit

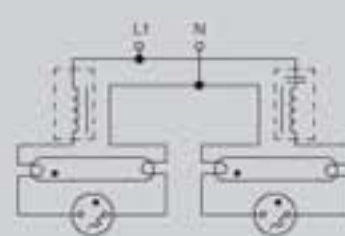

Circuit diagram (assembled)/
Installation plan

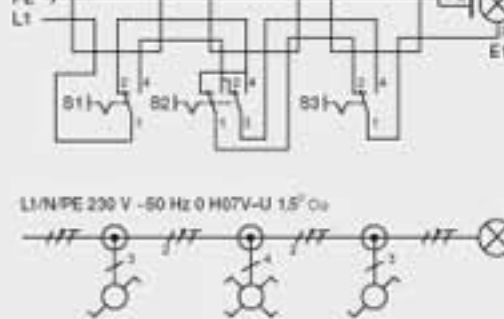

Circuit diagram (exploded)

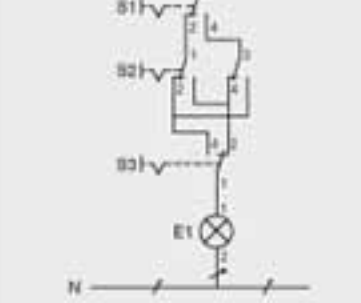

Capacitive tandem circuit

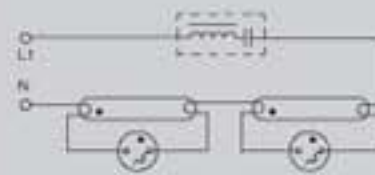

www.unitrain-i.com

www.lucas-nuelle.com

Lucas-Nülle GmbH
The education and training equipment company
Siemensstrasse 2
50170 Kerpen-Sindorf
Germany
Telephone: +49 2273 567-0

